

2" UL Full Port Premium Industrial Ball Valves (Supplemental Sheet)

Wabtec Corporation offers ball valves designed for rugged industrial applications including steam, water, oil, gas and corrosive materials.

Our ball valves are UL approved for flammable liquids, LP gas, natural and manufactured gas.

2 Way Forged Brass Ball Valve

Features:

- 400 WOG, quarter turn valve
- Non-vented
- Full port standard
- Teflon seals with adjustable stem packing material
- Heavy forged brass cast body and cap
- Heavy cast iron handle for durability

Benefits:

- We offer replacement kits
- Can withstand indoor and outdoor environments
- Certified by independent test labs at Underwriter Laboratories (UL)

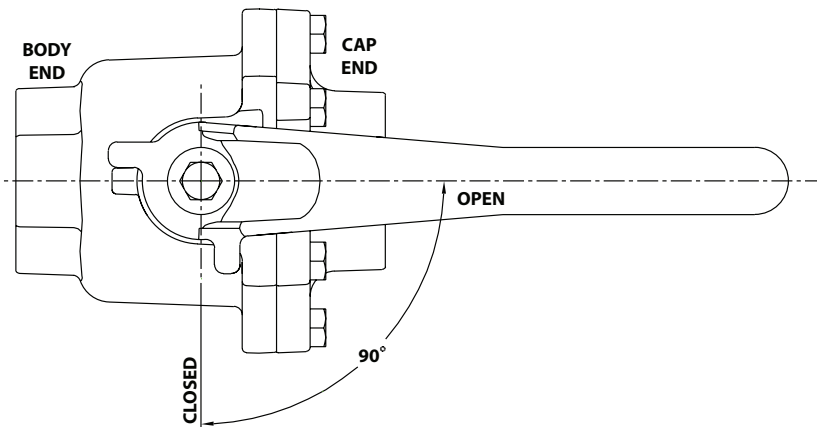
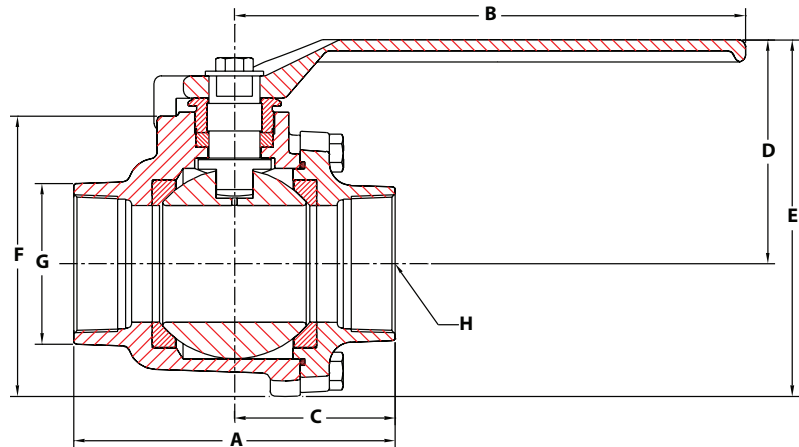

Type:	Teflon Seats & Seals, Packing Stem Seal
Size	2"
Port Opening	2"
A	5-1/2
B	8-3/4
C	2-3/4
D	3-3/4
E	6-1/8
F	4-9/16
G	2-3/4
H NPT	2-11-1/2
Part #	0308359

Call for information on repair kits!

Wabtec Corporation
1001 Air Brake Avenue
Wilmerding, PA 15148

412.825.1000
888.223.9792

valves@wabtec.com
www.wabtecvalves.com



Wabtec[®]
CORPORATION

WLP-0309-7
©2009 Wabtec Corporation